

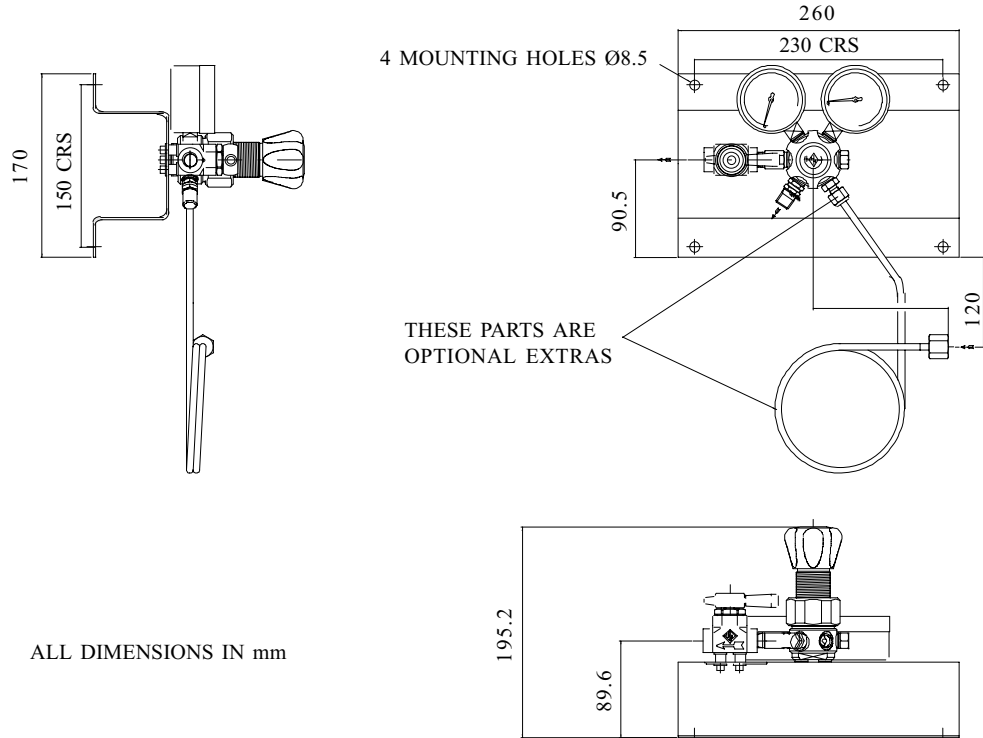

SERIES 24 HIGH PURITY

TYPE 1 - REGULATOR STATION FOR ONE BOTTLE WITH STOP VALVE

FOR CONTROLLING OF CORROSIVE AND NONCORROSIVE GASES IN SUPPLY SYSTEMS



ALL DIMENSIONS IN mm

SPECIFICATIONS: TYPE HH1

- Maximum inlet pressure: 200 barg, (2900 psig).
- Outlet pressure ranges: 0-5 barg (0-72.5 psig) - Relief Setting : 6.25 barg (90.1 psig)
0-10 barg (0-145 psig) - Relief Setting : 12.5 barg (181.2 psig)
0-30 barg (0-435 psig) - Relief Setting : 34.5 barg (500.3 psig)
- Medium: Corrosive and non-corrosive gases.
- Flow capacity: with HP 1500: 150 l/min. At 10 bar.
with HP 1100: 500 l/min. At 10 bar.
- Operating temperature: -40° C to +100°C.
- Connectors: Pigtail with connector according to DIN 477, BS 341, CGA, NPT 1/4" (F).

MATERIALS OF CONSTRUCTION:

Regulator:

- BODY: Stainless steel 316 or brass.
- SEAT AND SEAL: Stainless steel 316 & Kel-F®.
- DIAPHRAGM: Stainless steel 316 (optional Teflon® - coated).
- BONNET: Electroless nickel plated aluminium bar stock.

Stop Valve:

- BODY: Stainless steel 316 or brass.
- SEAT AND SEAL: Hastelloy & Kel-F®.
- DIAPHRAGM: Hastelloy.

OPTIONAL FEATURES:

- Suitable hand connector for gas bottle (DIN 477 BS 341.CGA).
- Burst disk safety device.
- Alternative materials available (monel, hastelloy, etc...)
- Contact gauges for alarm.
- Other pressure and flow rates on request.
- Two stage version.
- VCR version available.