



UHP3600

ULTRA HIGH PURITY STOP VALVE

KEY FEATURES AND BENEFITS:

- Manual and actuated versions are available based on a common body design.
- Manual version uses a fast, quarter turn action. Lever clearly shows valve status.
- Actuators are pneumatically operated with spring return. They are available in normally open or normally closed configurations.
- Suitable for most industrial gases including variants for oxygen and highly corrosive gases such as chlorine and HCl.
- Built to ultra high purity standards in a dedicated clean room facility. Final assembly and testing is carried out under class 10 conditions.
- Designed for the low leakage rates demanded by electronic gas users. Each valve is tested for leakage using a Mass Spectrometer.
- Non-tied diaphragm construction; the diaphragms act directly on the seat to close the valve, which minimises dead space and wetted area.
- Mechanically supported and retained valve seat to eliminate deformation under load and eliminate seat lift under reverse flow conditions.
- The diaphragm isolates the operating mechanism from the process fluids, it is of one-piece non-welded construction for greater integrity and improved fatigue life.
- To prevent the shedding of particulate contamination, there are no sliding, rotating or rubbing components in the flow path.
- Inlet and outlet port configurations are available to suit all known industry standards. The same valve family can be used for all fluids in all market areas.



SPECIFICATION:

- Working pressure 241bar (3500psi)
- Fluid Media: Industrial gases including toxic and corrosive gases and oxygen
- Nominal Bore: 4mm
- Cv: 0.2
- Operating temperature: -40 to +100°C
- Inboard Leak rate: less than 1×10^{-9} mbar l/s (200bar He)
- Outboard (gland) Leak rate: less than 1×10^{-9} mbar l/s (200bar He)
- Inlet/Outlet (seat) Leak rate: less than 1×10^{-9} mbar l/s (200bar He)
- Surface finish of wetted parts: 10 to 15 μ inch Ra

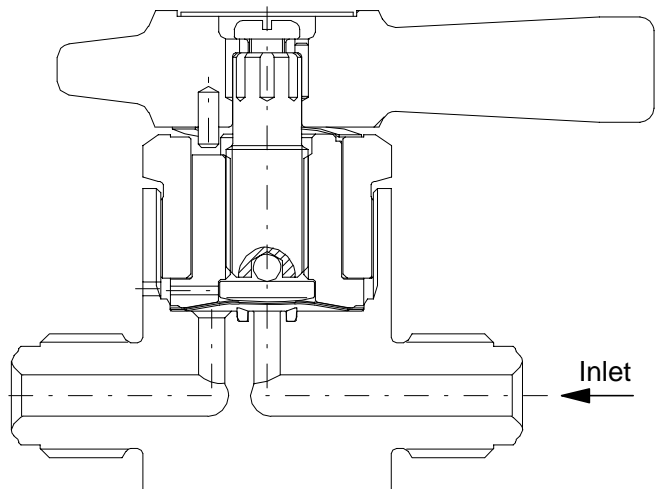

MATERIALS OF CONSTRUCTION:

- BODY - 316 stainless steel (electropolished)
- SEAT - PTFE
- DIAPHRAGM - Hastelloy C22

No lubrication is used in the flow path and the seat materials are chosen for minimal gas absorption. Please contact us for advice on material selection.

PORT OPTIONS:

- 1/4" VCR male or female, fixed or swivel
- 1/4" weld stub

Any combination of port configurations can be supplied on request.

ACTUATOR SPECIFICATION:

An actuated version is available for all valve variants. Variants of the actuator are available to hold the valve normally closed (opened by actuator pressure) or normally open (closed by actuator pressure). The valve is operated by applying pressure on the pilot port and returned by a spring.

- Pilot pressure: 5 to 7bar (75 to 100psi)
- Actuating medium: Air or Nitrogen
- Pilot Port: 1/8" NPT
- Materials of Construction: Hard Anodised Aluminium Alloy and Nickel Aluminium Bronze.

ORDER INFORMATION:

Manual Valve - UHP 3600S
 Actuated Valve - UHP 3620SA
 Actuator (Normally Closed) - LA 11
 Actuator (Normally Open) - LA 12

